



IMF™ Series II

IMF-12LF



Specifications

GENERAL SPECIFICATIONS

Nominal Impedance	8 Ω
Power	600 Watt (rms)
SPL 1W@1M average sensitivity	96 dB
Frequency Response	60Hz - 2000Hz
Dimension Ø x H (cm)	31.2 x 13.9
Net Weight	8.8 kg (19.4 lbs)
Shipping Weight	10 kg (22.0 lbs)
Packing Dimension H x W x D (cm)	34.5 x 34.5 x 18.5 (0.8cu.ft)
	13.6" x 13.6" x 7.3"

PHYSICAL SPECIFICATIONS

Magnet type	Ferrite
Voice Coil Diameter	76.2 mm (3 inch)

THIELE/SMALL PARAMETERS

Resonance Frequency	Fs	37 Hz
DC. Resistance	Re	5.9 Ω
Coil Inductance	Le	0.344 mH
Mechanical Q Factor	Qms	1.57
Electrical Q Factor	Qes	0.33
Total Q Factor	Qts	0.27
BL Product	BL	18.54 Tm
Effective Moving Mass	Mms	82.84 g
Equivalent Cas Air-Load	Vas	89.72 Liters
Effective Piston Area	Sd	0.0530 Sqm
Half-Space Efficiency	Eff	1.33 %
Airgap Height	Hag	10.0 mm
Voice Coil Height	Hvc	18.0 mm
Voice Coil Overhang	Xmax	4.0 mm

Applications

IMF-12LF

The IMF Series II 12LF is a 12 inch (312mm) diameter loudspeaker optimized for use in high performance two way sound reinforcement systems. The IMF-12LF features a Ferrite based permanent magnetic system. The magnetic design was developed using P Audio's finite element analysis software and fully tested using advanced computer based measurement and analysis systems. The IMF-12LF has been designed to provide very high sound pressure level performance in the 60Hz to 2000Hz range and is ideally suited for integration into modern two way 12 inch system designs. The transducer is well suited for applications where the high frequency response is provided by a professional level compression driver and horn combination.

The IMF-12LF utilizes a 3 inch (76.2mm) diameter voice coil design. The voice coil conductor is high conductivity copper and winding dimensions have been designed to compliment the linear excursion parameters necessary for high level operation in the rated bandwidth. The cone design features a newly developed material that improves mid band vocal response and clarity by increasing the internal mechanical damping of the vibrating system. System power handling is very high and provides excellent field reliability, particularly with the typical high level inputs found in modern sound reinforcement and public address systems.

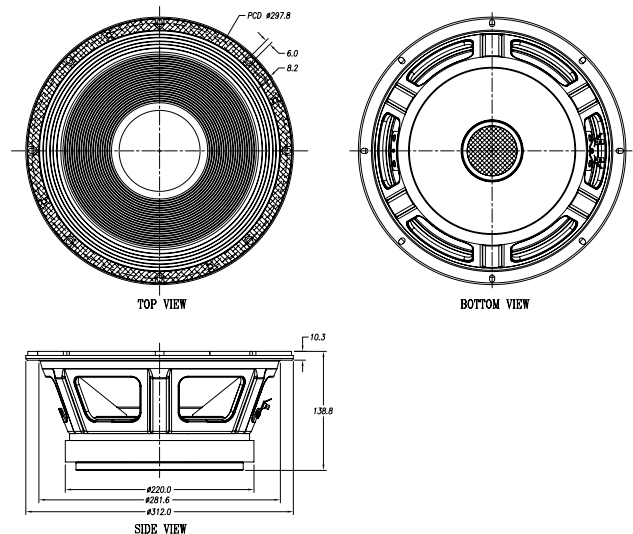

dB SPL

SPL vs FREQ

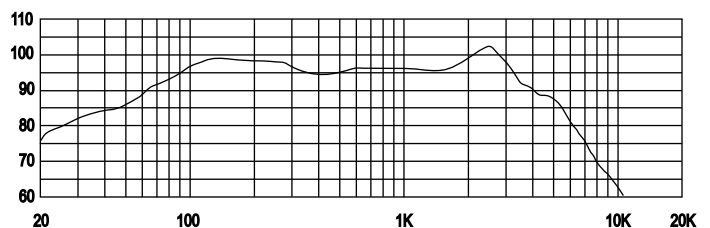

Frequency Response

19/4 Moo 2 T.Bangkratuk A.Samparn Nakornpathom 73210 Thailand
 Tel: +66-2-441-6600 Auto 30 Lines
 e-mail: info@paudiothailand.com
 Website: www.paudiothailand.com
 All rights reserved by P.Audio System Co.,Ltd. 2007

