



# IMF™ Series II

# IMF-15LF



## Applications

### IMF-15LF

The IMF Series II offers a 15 inch (389mm) diameter transducer designed for use in two way portable sound reinforcement systems. The IMF-15LF is a Ferrite based permanent magnetic system design that features a 3 inch (76.2mm) voice coil diameter that provides both very high power handling and very high reliability. The rigid stamped steel chassis provides secure mounting and a high degree of mechanical support for the loudspeaker.

The IMF-15LF is designed with an operating bandwidth of 50Hz to 1500Hz and has been optimized for use within this rated frequency range. This makes the device ideal for use as a woofer in modern two way systems where the high frequency response is provided by a professional level high acoustic output compression driver and horn combination. The IMF-15LF uses a newly developed cone material that provides improved mid range response in both the frequency domain and the time domain. This new material offers more vocal range clarity and intelligibility.

All IMF Series II loudspeakers are fully optimized designs that benefit from state of the art analysis and design tools. The reliability and consistency of the IMF-15LF is a direct result of P Audio's precise manufacturing methods and quality systems.

## Specifications

### GENERAL SPECIFICATIONS

Nominal Impedance	8 Ω
Power	800 Watt (rms)
SPL 1W@1M average sensitivity	97 dB
Frequency Response	50Hz - 1500Hz
Dimension Ø x H (cm)	38.9 x 15.8
Net Weight	9.3 kg (20.5 lbs)
Shipping Weight	10.9 kg (24.0 lbs)
Packing Dimension H x W x D (cm)	42.5 x 42.5 x 20.5 (1.3cu.ft)
	16.7" x 16.7" x 8.1"

### PHYSICAL SPECIFICATIONS

Magnet type	Ferrite
Voice Coil Diameter	76.2 mm (3 inch)

### THIELE/SMALL PARAMETERS

Resonance Frequency	Fs	47.6 Hz
DC Resistance	Re	6.1 Ω
Coil Inductance	Le	0.485 mH
Mechanical Q Factor	Qms	6.39
Electrical Q Factor	Qes	0.64
Total Q Factor	Qts	0.58
BL Product	BL	17.82 Tm
Effective Moving Mass	Mms	109.81 g
Equivalent Cas Air-Load	Vas	105.87 Liters
Effective Piston Area	Sd	0.0850 Sqm
Half-Space Efficiency	Eff	1.72 %
Airgap Height	Hag	8.0 mm
Voice Coil Height	Hvc	14.0 mm
Voice Coil Overhang	Xmax	2.0 mm

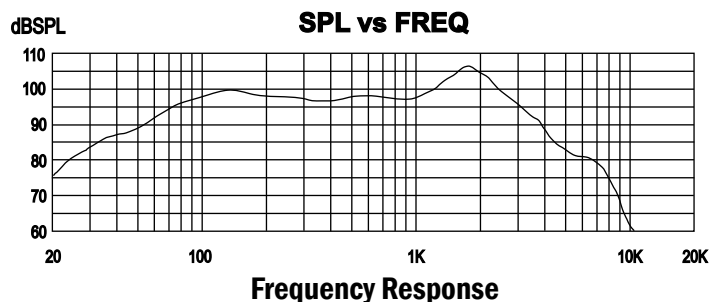
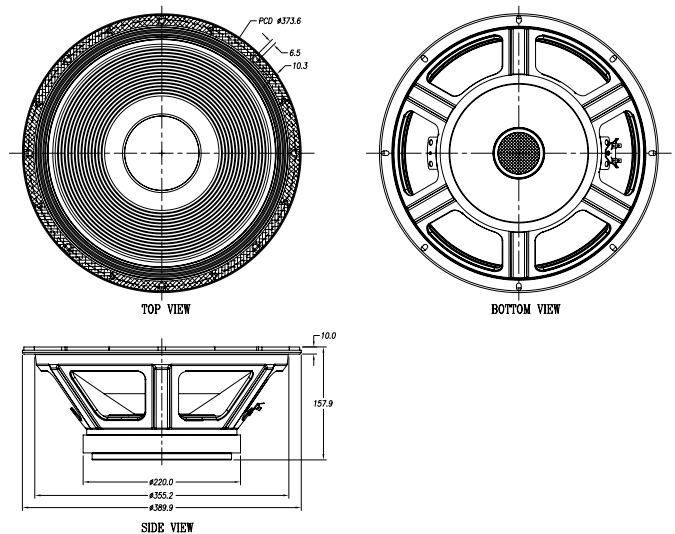

19/4 Moo 2 T.Bangkratuk A.Samparn Nakornpathom 73210 Thailand  
 Tel: +66-2-441-6600 Auto 30 Lines  
 e-mail: info@paudiothailand.com  
 Website: www.paudiothailand.com  
 All rights reserved by P.Audio System Co.,Ltd. 2007

