



IMF™ Series II

IMF-18W



Specifications

GENERAL SPECIFICATIONS

Nominal Impedance	8 Ω
Power	600 Watt (rms)
SPL 1W@1M average sensitivity	97 dB
Frequency Response	30Hz - 125Hz
Dimension Ø x H (cm)	46.0 x 19.6
Net Weight	9.9 kg (21.8 lbs)
Shipping Weight	11.9 kg (26.2 lbs)
Packing Dimension H x W x D (cm)	49.5 x 49.5 x 24.5 (2.1cu.ft)
	19.5" x 19.5" x 9.6"

PHYSICAL SPECIFICATIONS

Magnet type	Ferrite
Voice Coil Diameter	76.2 mm (3 inch)

THIELE/SMALL PARAMETERS

Resonance Frequency	Fs	34 Hz
DC. Resistance	Re	6.1 Ω
Coil Inductance	Le	0.474 mH
Mechanical Q Factor	Qms	7.254
Electrical Q Factor	Qes	0.72
Total Q Factor	Qts	0.65
BL Product	BL	17.38 Tm
Effective Moving Mass	Mms	162.33 g
Equivalent Cas Air-Load	Vas	259.10 Liters
Effective Piston Area	Sd	0.1257 Sqm
Half-Space Efficiency	Eff	1.49 %
Airgap Height	Hag	10.0 mm
Voice Coil Height	Hvc	14.0 mm
Voice Coil Overhang	Xmax	2.0 mm

Applications

IMF-18W

The IMF Series II features a wide range of transducers, each designed for specific applications. The IMF-18W is a high performance sub woofer designed for use in dance club systems, mobile DJ systems and portable sound reinforcement sub designs.

The IMF-18W is an 18 inch (460mm) diameter loudspeaker that features a rigid stamped steel chassis coupled to a large format Ferrite based permanent magnetic system.

The IMF-18W was designed to produce high impact sub bass response. The 3 inch diameter (76.2mm) voice coil design features high conductivity copper and very high thermal capacity adhesive systems to insure both high power handling and high reliability. The IMF-18W features an optimized voice coil geometry designed to support the high excursion requirements of modern high impact sub woofers.

Computer based modeling and analysis techniques have optimized the rated bandwidth of 30Hz to 125Hz. This rated bandwidth makes the IMF-18W ideal for reproducing the high impact acoustic response found in modern sound reinforcement systems.

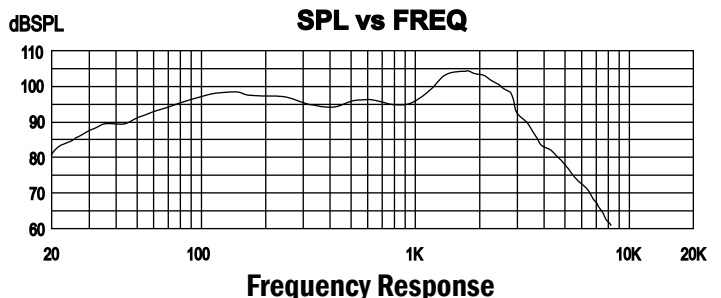
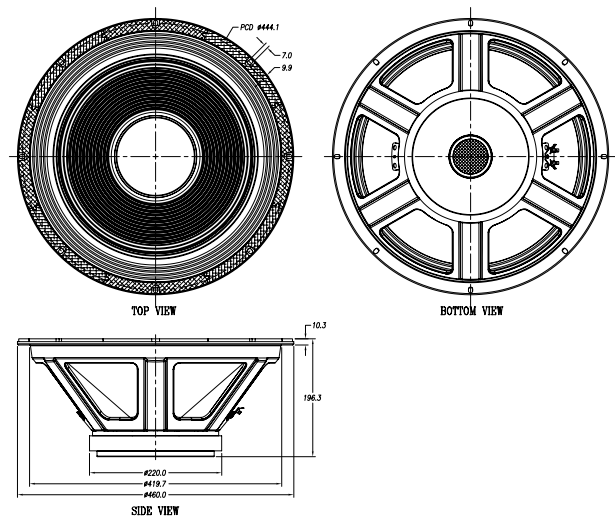

19/4 Moo 2 T.Bangkratuk A.Samparn Nakornpathom 73210 Thailand
 Tel: +66-2-441-6600 Auto 30 Lines
 e-mail: info@paudiothailand.com
 Website: www.paudiothailand.com
 All rights reserved by P.Audio System Co.,Ltd. 2007

